

# RT 880

## Product Guide



**ROUGH TERRAIN HYDRAULIC CRANE**

### Features

- **MAX. CAPACITY (Outriggers)** - 75.0 Tonnes at 3m Radius (85% Rating) 360° Slew
- **MAX. CAPACITY (On Tyres)** - 32.3 Tonnes at 3m Radius (85% Rating) over front
- **BOOM** - 4 Section Trapezoidal 11.0m to 34.6m
- **MAXIMUM ROAD SPEED** - 30 km/hr
- **CARRIER** - 4 X 4 wheel drive with 4 wheel steer

# Superstructure Specification

## **BOOM**

11.0m - 34.6m total length four section telescopic trapezoidal full power boom. Fabricated from high strength low alloy steel plates. Telescopic sections slide on adjustable and replaceable low friction wear pads.

## **BOOM NOSE**

Six nylatron sheaves mounted on heavy duty tapered roller bearings with removable pin-type rope guards fitted with standard removable type auxiliary boom nose.

**Maximum tip height:** 37.1m

## **BOOM ELEVATION**

Two double acting hydraulic cylinders with integral holding valves.

## **BOOM ANGLE**

Maximum: 80°, Minimum: -4°

## **SUPERSTRUCTURE FRAME**

Fabricated from high tensile steel plates and sections.

## **SLEW SYSTEM**

Ball bearing swing circle with 360° continuous rotation. Planetary "Glide-Swing" with foot applied multi-disc wet brake. Spring applied hydraulically released parking brake. Mechanical house lock operated from cab. Free slew facility provided.

## **SLEW SPEED**

Limited to 1.5 RPM (Unladen)

## **HOIST SYSTEM**

Power up and down, equal speed, grooved drum, planetary reduction with integral automatic spring applied multidisc brake. Hoist drum fitted with third wrap indicator.

**Non Spin Hoist Rope:** 19mm dia. & length 229m.

**Line Speed:** Top layer 130m/min (max) Unladen.

**Maximum Permissible Line Pull:** 5860 kg.

## **HOOK BLOCK**

75.0 Tonnes, 6 sheaves plus 1 on Aux. boom nose - 13 falls

## **COUNTERWEIGHT**

Bolted with superstructure.

**Weight** – 6078 kg. (w/o swingaway extension)

**Weight** – 7440 kg. (with swingaway extension)

## **OPERATOR'S CAB**

Totally enclosed steel construction, full vision type, joystick control for all crane functions, driving controls, engine instrumentation & automotive type steering

wheel. All windows fitted with toughened safety glass, lockable sliding door, cab interior light, circulating air fan, pantograph type electric wiper & electric horn. Adjustable operator's seat with ergonomically designed cab and controller layout to give fatigue free comfort to the operator.

## **LMI & A2B SYSTEM**

Load Moment Indicator and Anti-Two Block system with audio-visual warning and control lever lockout provides electronic display of boom angle, boom length, radius, relative load moment, permissible load, load indication & warning of impending two-block condition.

## **HYDRAULIC SYSTEM**

**Pumps** - One 3 Section & one Single-Section Gear pump driven through transmission PTO & One Single-section Gear pump driven through engine PTO.

**Valves** - Precision four way double acting pilot operated control valves. Four individual valve banks permit simultaneous control of multiple crane functions.

**Filter** - Return line filter with replaceable cartridge having full flow with bypass protection and service indicator.

**Reservoir** - 852 liters with spin-on breather filter, external sight gauge, clean out access, strap mounted to frame.

**Oil Cooler** - Remote mounted, thermostatically controlled hydraulic motor driven fan.

**Pressure Check Panel** - System pressure test panel with quick release type fittings for verification of circuit pressure.

## **OPTIONAL EQUIPMENT**

### **Fixed Swingaway Extension**

10.0m lattice swingaway boom extension with integral offset mechanism, off settable at 2°, 15° or 30°. Stows alongside base boom section when not in use.

**Maximum tip height :** 46.6m

### **Tele Swingaway Extension**

10.0m – 17.7m telescopic lattice swingaway boom extension with integral offset mechanism, off settable at 2°, 15° or 30°. Stows alongside base boom section when not in use.

**Maximum tip height :** 55.1m

Single Sheave Hook Block – 15Te

Auxiliary Hoist Unit

Protective Super Cab (FOP)

Air Conditioned Cab

360° rotating Beacon Lamp

Man-carrying Basket

# Height of Lift : 11.0m-34.6m Full Power Boom with 10.0m - 17.7m Tele Extension

WORKING RANGE DIAGRAM  
(BOOM DEFLECTION NOT SHOWN)

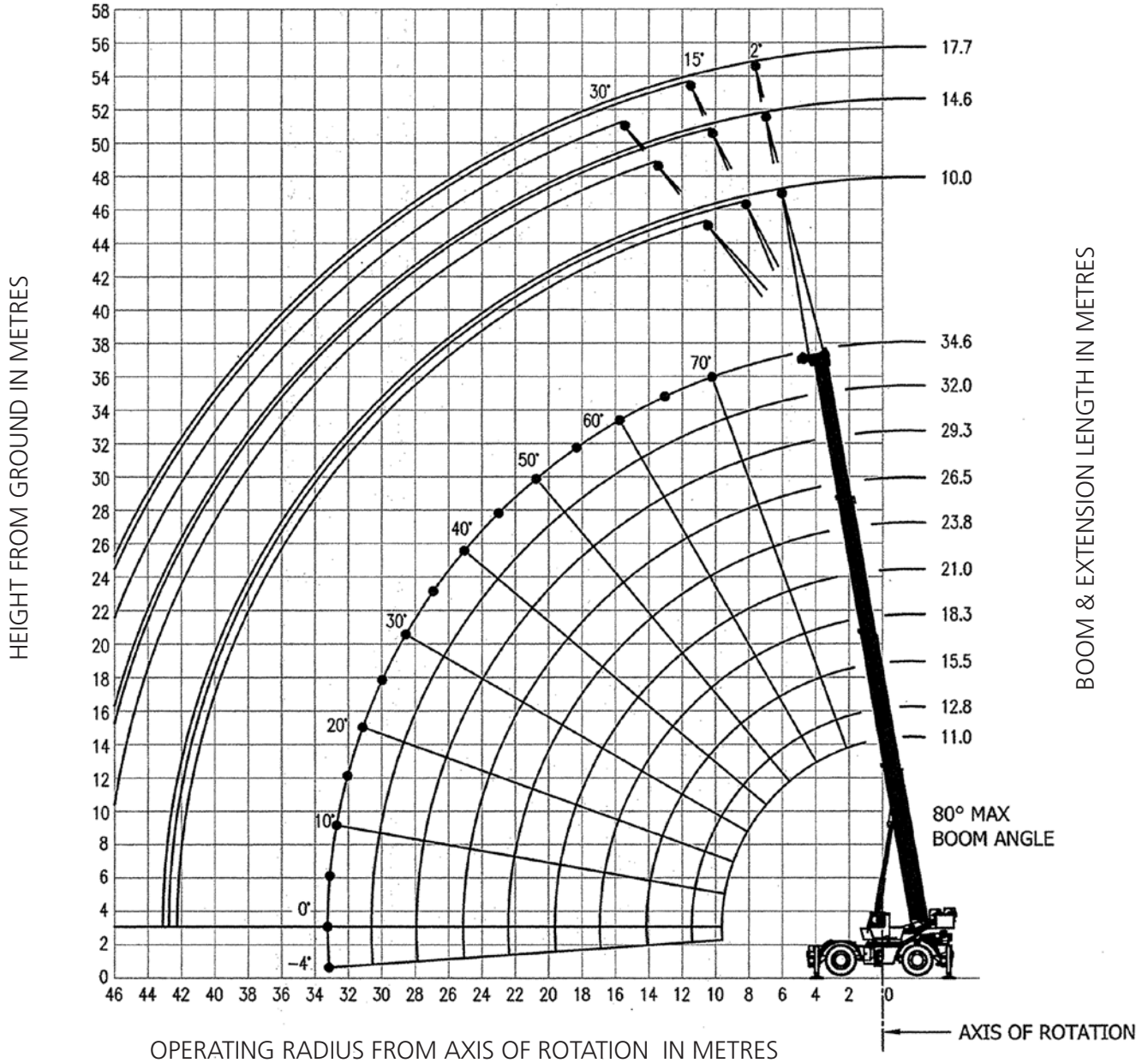

NOTE:  
The above heights of lift and boom angles are based on a straight (unladen) boom and allowance should be made for boom deflections obtained under laden conditions.

## Hookblock Capacities and Weights - Tonnes

No of Falls	13	12	11	10	9	8	7	6	5	4	3	2	1
Permissible Load	75.0	69.0	63.0	57.0	51.0	45.0	39.0	33.0	27.0	21.5	16.0	10.5	5.0
Weight of Hook block	1.01	1.01	1.01	1.01	1.01	1.01	1.01	1.01	1.01	1.01	1.01	0.42	0.23

RT 880

# Lifting Capacities (Metric) 85% Rating 4 Section Boom Duties (in Kilograms)

## Main Boom - On Outriggers Fully Extended - 360°

Radius in Meters	Main Boom Length (in Meters)									
	11.0	12.8	15.5	18.3	21.0	23.8	26.5	29.3	32.0	34.6
3.0	*75,000 (67)	48,395 (70.5)	46,080 (74)	45,355 (77)	43,860 (79)					
3.5	60,000 (64)	48,395 (68)	46,080 (72.5)	44,315 (75.5)	40,775 (77.5)	38,415 (79.5)				
4.0	51,365 (61)	48,395 (65.5)	45,085 (70.5)	42,025 (73.5)	38,165 (76.5)	37,215 (78.5)				
4.5	47,445 (58)	47,170 (63)	43,475 (68.5)	38,940 (72)	36,195 (75)	35,435 (77)	29,255 (79)			
5.0	43,815 (54.5)	43,815 (60.5)	41,455 (66.5)	36,215 (70.5)	34,060 (73.5)	33,540 (76)	28,210 (78)			
6.0	37,145 (48)	37,145 (55)	37,080 (62)	32,295 (67)	29,550 (70.5)	29,345 (73.5)	25,215 (75.5)	23,540 (77.5)	21,975 (79)	17,515 (80)
7.0	31,455 (40)	31,455 (49.5)	31,455 (58)	29,210 (63.5)	26,080 (67.5)	24,855 (70.5)	22,290 (73.5)	21,135 (75.5)	20,000 (77)	16,235 (78.5)
8.0		26,535 (43)	26,535 (53)	25,965 (60)	23,605 (64.5)	21,475 (68)	19,820 (71)	19,095 (73.5)	17,980 (75)	14,945 (76.5)
9.0		22,475 (35.5)	22,475 (48.5)	22,475 (56)	21,475 (61.5)	19,615 (65.5)	17,980 (68.5)	17,620 (71)	16,260 (73)	13,875 (75)
10.0		19,390 (26)	19,390 (43)	19,390 (52)	19,250 (58)	17,960 (62.5)	16,420 (66.5)	15,920 (69)	14,760 (71.5)	12,925 (73)
12.0			16,000 (30)	16,000 (43.5)	16,000 (51.5)	15,145 (57)	13,605 (61.5)	13,265 (64.5)	12,425 (67.5)	11,335 (69.5)
14.0				12,228 (32.5)	12,230 (43.5)	12,220 (51)	11,480 (56)	11,340 (60)	10,610 (63.5)	10,090 (66)
16.0				9,460 (16)	9,440 (34.5)	9,430 (44)	9,430 (50.5)	9,430 (55.5)	9,000 (59)	8,810 (62)
18.0					7,560 (22.5)	7,550 (36)	7,540 (44.5)	7,530 (50.5)	7,530 (55)	7,530 (58)
20.0						6,220 (26)	6,200 (37.5)	6,190 (44.5)	6,190 (50)	6,180 (54)
23.0							4,540 (23.5)	4,530 (35)	4,530 (42)	4,530 (47.5)
26.0								3,240 (21.5)	3,230 (33)	3,220 (39.5)
29.0									2,110 (19)	2,110 (30)
32.0										1,160 (15.5)
Minimum boom angle (deg.) for indicated length (no load)										0
Maximum boom length (m) at 0 degree boom angle (no load)										34.6

Note : ( ) Boom angles are in degrees.

\*13 parts of the line required to lift this capacity (using aux. boom nose). Refer to Operators & Safety Handbook for reeving diagram

## Weight Reduction for Load Handling Devices

10.0m Fixed Boom Extension	
* Stowed	356 kg
* Erected	2,843 kg

10.0m - 17.7m Tele Boom Extension	
*Stowed	492 kg
*Erected (Retracted)	4,228 kg
*Erected (Extended)	5,833 kg
AUXILIARY BOOM HEAD	142 kg

Hookblocks and Headache Balls	
75 Te - 6 Sheaves	**1010 kg.
15 Te - 1 Sheave	**418 kg.
10 Te - Headache Ball	**227 kg.

\*Reduction of main boom capacities  
\*\* Ref. to rating plate of Hook-block

# Lifting Capacities (Metric) 85% Rating Swingaway Duties (in Kilograms)

## 10.0m Swingaway - 360°

Radius (in Meters)	10.0m length		
	2° Offset	15° Offset	30° Offset
7	*10,425 (80)		
8	10,100 (79.5)		
9	9,305 (78)	*7,115 (80)	
10	8,575 (76.5)	6,760 (79)	*5,210 (80)
12	7,445 (74)	5,865 (76.5)	5,085 (79.5)
14	6,735 (71)	5,120 (73.5)	4,535 (76.5)
16	6,065 (68.5)	4,545 (70.5)	4,060 (73.5)
18	5,365 (65.5)	4,060 (68)	3,670 (70.5)
20	4,775 (62.5)	3,640 (65)	3,330 (67.5)
22	4,265 (59.5)	3,280 (61.5)	3,030 (64.5)
24	3,770 (56.5)	2,970 (58.5)	2,765 (61)
26	3,340 (53)	2,700 (55.5)	2,535 (57.5)
28	2,985 (49.5)	2,460 (52)	2,325 (54)
30	2,450 (46)	2,245 (48.5)	2,135 (50)
32	1,950 (42)	2,060 (44.5)	1,970 (46)
34	1,515 (37.5)	1,685 (40)	1,825 (41.5)

Note : ( ) Boom angles are in degrees.  
\* This capacity is based upon the maximum boom angle.

## 10.0m - 17.7m Tele Swingaway - 360°

Radius (in Meters)	10.0m Extension			14.6m Extension			17.7m Extension		
	2° Offset	15° Offset	30° Offset	2° Offset	15° Offset	30° Offset	2° Offset	15° Offset	30° Offset
7	*10,200								
8	9,855			*7,030					
9	9,060	*6,870		6,815			*4,670		
10	8,330	6,515	*4,965	6,305	*4,535		4,585		
12	7,200	5,620	4,840	5,360	4,420		4,275	*3,525	
14	6,490	4,875	4,290	4,600	3,910	*3,235	3,960	3,365	
16	5,820	4,300	3,815	4,015	3,460	3,015	3,490	3,000	*2,505
18	5,120	3,815	3,425	3,535	3,085	2,720	3,065	2,680	2,345
20	4,530	3,395	3,085	3,125	2,765	2,465	2,720	2,410	2,135
22	4,020	3,035	2,785	2,775	2,490	2,245	2,435	2,180	1,945
24	3,525	2,725	2,520	2,475	2,245	2,045	2,190	1,975	1,780
26	3,095	2,455	2,290	2,215	2,030	1,865	1,965	1,795	1,630
28	2,680	2,215	2,080	1,990	1,840	1,705	1,775	1,630	1,490
30	2,095	2,000	1,890	1,795	1,670	1,560	1,605	1,485	1,370
32	1,595	1,805	1,725	1,615	1,520	1,430	1,450	1,350	1,260
34	1,160	1,340	1,480	1,455	1,385	1,310	1,315	1,230	1,155
36				1,295	1,260	1,200	1,195	1,120	1,060
38				950	1,145	1,100	1,080	1,025	975
40							935	935	895

\* This capacity is based upon the maximum boom angle.

# Lifting Capacities (Metric) 85% Rating 4 Section Boom Duties (in Kilograms)

## Main Boom - On Rubber (Stationary – Defined Arc Over Front)

Radius (in Meters)	Main Boom Length in Meters							
	Tyre Pressure – 5.3 Bar							
	11.0	12.8	15.5	18.3	21.0	23.8	26.5	29.3
3.0	32,300 (67)	14,600 (70.5)	14,600 (74)					
3.5	29,600 (64)	14,600 (68)	12,400 (72.5)					
4.0	27,000 (61)	14,600 (65.5)	11,400 (70.5)					
4.5	24,800 (58)	14,600 (63)	11,000 (68.5)	9,300 (72)	9,300 (75)			
5.0	22,800 (54.5)	14,600 (60.5)	11,000 (66.5)	9,300 (70.5)	9,300 (73.5)			
6.0	19,500 (48)	14,600 (55)	11,000 (62)	9,300 (67)	9,300 (70.5)			
7.0	16,800 (40)	14,600 (49.5)	11,000 (58)	7,750 (63.5)	7,750 (67.5)			
8.0		14,600 (43)	11,000 (53)	7,750 (60)	7,750 (64.5)			
9.0		12,650 (35.5)	10,300 (48.5)	7,750 (56)	7,750 (61.5)			
10.0		11,000 (26)	10,200 (43)	7,750 (52)	7,750 (58)			
12.0			7,600 (30)	7,600 (43.5)	6,750 (51.5)	6,550 (57)	4,700 (61.5)	
14.0				5,600 (32.5)	4,500 (43.5)	4,500 (51)	4,500 (56)	4,000 (60)
16.0				4,000 (16)	4,000 (34.5)	3,500 (44)	3,500 (50.5)	3,500 (55.5)
18.0					2,900 (22.5)	2,900 (36)	2,500 (44.5)	2,500 (50.5)
20.0						2,100 (26)	2,100 (37.5)	1,700 (44.5)
23.0							1,000 (23.5)	1,000 (35)

Note : ( ) Boom angles are in degrees.

# Lifting Capacities (Metric) 85% Rating 4 Section Boom Duties (in Kilograms)

## On Rubber (Pick & Carry Capacities – Upto 4.0 km/hr Boom Centered Over Front)

Radius (in Meters)	Main Boom Length in Meters						
	Tyre Pressure – 4.48 Bar						
	11.0	12.8	15.5	18.3	21.0	23.8	26.5
3.0	30,300 (67)	15,800 (70.5)					
3.5	27,400 (64)	15,800 (68)					
4.0	24,800 (61)	15,800 (65.5)					
4.5	22,400 (58)	15,800 (63)					
5.0	20,500 (54.5)	15,400 (60.5)					
6.0	17,300 (48)	13,300 (55)	13,150 (62)				
7.0	14,800 (40)	13,000 (49.5)	11,000 (58)				
8.0		12,750 (43)	9,300 (53)				
9.0		11,300 (35.5)	7,750 (48.5)	7,700 (56)			
10.0		9,800 (26)	7,600 (43)	7,600 (52)	7,500 (58)		
12.0			7,600 (30)	6,500 (43.5)	5,000 (51.5)	4,900 (57)	
14.0				5,500 (32.5)	3,600 (43.5)	3,600 (51)	3,600 (56)
16.0				3,900 (16)	2,500 (34.5)	2,500 (44)	2,500 (50.5)
18.0					1,500 (22.5)	1,450 (36)	1,450 (44.5)
20.0						900 (26)	900 (37.5)

Note : ( ) Boom angles are in degrees.

## On Rubber (Stationary Capacities - 360°)

Radius (in Meters)	Main Boom Length in Meters				
	Tyre Pressure – 5.3 Bar				
	11.0	12.8	15.5	18.3	21.0
3.0	20,970 (67)	14,600 (70.5)	14,600 (74)		
3.5	18,325 (64)	13,225 (68)	12,400 (72.5)		
4.0	16,325 (61)	11,500 (65.5)	11,400 (70.5)		
4.5	14,650 (58)	10,150 (63)	10,150 (68.5)	9,300 (72)	9,300 (75)
5.0	12,880 (54.5)	9,615 (60.5)	9,135 (66.5)	9,135 (70.5)	9,135 (73.5)
6.0	10,115 (48)	8,705 (55)	7,710 (62)	7,710 (67)	7,710 (70.5)
7.0	7,530 (40)	7,530 (49.5)	6,210 (58)	6,210 (63.5)	6,210 (67.5)
8.0		5,910 (43)	5,080 (53)	4,830 (60)	4,830 (64.5)
9.0		4,610 (35.5)	4,445 (48.5)	3,670 (56)	3,670 (61.5)
10.0		3,610 (26)	3,610 (43)	2,945 (52)	2,945 (58)
12.0			2,250 (30)	2,250 (43.5)	1,910 (51.5)
14.0				1,260 (32.5)	1,270 (43.5)
16.0					577 (34.5)

Note : ( ) Boom angles are in degrees.

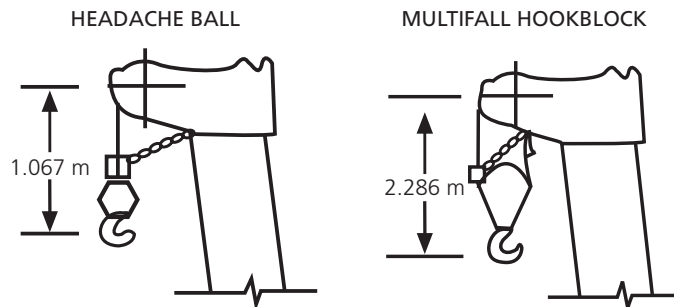

Dimensions are for largest furnished hook block and headache ball with anti-two block activated.

# Zero Degree Boom Angle Charts

## On Outriggers - 360 Degrees

Boom Angle	Main Boom Length in Meters							
	11.0	12.8	15.5	18.3	21.0	23.8	26.5	29.3
0°	11,150 (9.2)	8,805 (11.0)	6,330 (13.8)	4,595 (16.5)	3,310 (19.3)	2,325 (22.0)	1,535 (24.8)	895 (27.5)

Note: ( ) Reference radii in metres

## On Rubber

Boom Angle	Stationary Capacity Defined Arc Over Front							
	Main Boom Length in Meters							
	11.0	12.8	15.5	18.3	21.0	23.8	26.5	
0°	10,750 (9.2)	8,805 (11.0)	5,700 (13.8)	3,600 (16.5)	2,250 (19.3)	1,250 (22.0)	500 (24.8)	

Note: ( ) Reference radii in metres

Boom Angle	Stationary Capacity 360° Arc		
	Main Boom Length in Meters		
	11.0	12.8	15.5
0°	4,600 (9.2)	2,800 (11.0)	1,250 (13.8)

Note: ( ) Reference radii in metres

Boom Angle	Pick & Carry Capacities Up to 4.0 KPH Boom Centered Over Front				
	Main Boom Length in Meters				
	11.0	12.8	15.5	18.3	21.0
0°	11,150 (9.2)	8,805 (11.0)	6,030 (13.8)	2,165 (16.5)	1,135 (19.3)

Note: ( ) Reference radii in metres



# Notes

## NOTES FOR LIFTING CAPACITIES

**WARNING: THIS CHART IS ONLY A GUIDE.** The Notes below are for illustration only and should not be relied upon to operate the crane. The individual crane's load chart, operating instructions and other instruction plates must be read and understood prior to operating the crane.

1. All rated loads have been tested to meet minimum requirements of IS: 4573 – 1982 Specification for Power Driven Mobile Cranes and do not exceed 85% of the tipping load on outriggers (85% of the tipping load on rubber) as determined by SAE J765 OCT80 Crane Stability Test Code.
2. Capacities given do not include the weight of hookblocks, slings, auxiliary lifting equipment and load handling devices. Their weights MUST be added to the load to be lifted. When more than minimum required reeving is used, the additional rope weight shall be considered part of the load.
3. Load ratings are based on freely suspended loads. No attempt shall be made to move the load horizontally on the ground in any direction.
4. Defined Arc  $\pm 6^\circ$  on either side of longitudinal centerline of machine.
5. Capacities appearing above the bold line are based on structural and tipping should not be relied upon as a capacity limitation.
6. All capacities are for crane on firm, level surface. It may be necessary to have structural supports under the outrigger floats or tyres to spread the load to a larger bearing surface.
7. When either boom length or radius or both are between values listed, the smallest load shown at either the next larger radius or boom length shall be used.
8. Unless otherwise stated, capacities are with powered boom sections equally extended.
9. For outrigger operation, all outriggers shall be fully extended with tyres raised free of the ground before raising the boom or lifting loads.
10. Tyres shall be inflated to the recommended pressure before lifting on rubber.
11. Axle lockout must be functioning before lifting on rubber.
12. On rubber, lifting with boom extension is not permitted.
13. For Pick & Carry operation, boom must be centered over front of the machine, mechanical swing-lock engaged and load restrained from swinging. When handling loads in the structural range with capacities close to maximum rating, travel should be reduced to creep speed (not over 61m movement in 30 min., not exceeding 1.6 km/hr.)

**WARNING – Operation of the machine with heavier load than the capacities listed is strictly prohibited. Machine tipping occurs without advance warning.**

# Carrier Specification

## FRAME

High strength alloy steel welded box section with integral outrigger housings and front / rear lifting, towing and tie down lugs.

## OUTRIGGER SYSTEM

Four hydraulic telescopic beams with jacks having integral holding valves, positioned two nos. in each outrigger housing, provides steel fabricated quick release type outrigger float for each jack.

## OUTRIGGER CONTROLS

Independent control of each outrigger beam located in cab on front dash panel along with level indicator.

## ENGINE

Volvo TAD851VE, 252 HP @ 2200 RPM,  
Max Torque : 1160 Nm @ 1350 rpm  
Emission : BSIII CEV

## FUEL TANK

Capacity 379 liters.

## ELECTRICAL SYSTEM

Two 12 Volt batteries, 12 Volt lighting equipment including two head lights, side, tail and stop lights and flashing indicators.

## DRIVE

4x4 / 4x2

## STEERING

Fully independent power steering:

**Front** : Full hydraulic controlled by steering wheel.

**Rear** : Full hydraulic selector switch controlled.

Provides infinite variations of 4 main steering modes – front only, rear only, crab & coordinated.

Provides rear wheel steer indicator.

**Steering Reversal** - Provided to have same conventional steering control effect, irrespective of super position with respect to carrier.

## TRANSMISSION

Engine mounted full power shift with 6 forward and 6 reverse speeds. Provides front axle disconnect for 4 x 2 travel.

## AXLES

**Front:** Drive-steer with differential and planetary reduction hubs, rigidly mounted to the chassis frame.

**Rear:** Drive-steer with differential and planetary reduction hubs, pivot mounted at the centre of the chassis frame.

## OSCILLATION LOCKOUT

Automatic full hydraulic lockouts on rear axle permits oscillation only with boom centered over front.

## BRAKES

Dual braking system, full hydraulic operating on all wheels. Spring applied, hydraulically released parking brake operating on front axle.

## TYRES

29.5 X 25 – 28 PR – E3 Tread earthmover tyres.

## INSTRUMENTATION

Engine oil pressure gauge, Fuel gauge, Water temperature gauge, Voltmeter, Tacho-Hourmeter, Warning lights and switches for control.

## MAXIMUM SPEED

30 kmph.

## GRADEABILITY

45% (Maximum) Unladen

## GROSS VEHICLE WEIGHT & AXLE LOADS (approx.)

**Front Axle** – 25,600 kg.

**Rear Axle** – 25,500 kg.

**GVW** – 51,100 kg.

## Optional Weights (approx.)

Fixed Lattice : 1400 kg

Tele lattice : 1800 kg

Auxiliary Hoist : 750 kg

## MISCELLANEOUS STANDARD EQUIPMENT

Full width steel fenders, rear view mirror, back-up alarm, front stowage well, tool kit.

## OPTIONAL EQUIPMENT

Fire Extinguisher

Pintle Hook – Front / Rear

Centralized Lubrication System

Semi-automatic Fire suppression System

# GA Drawing

## Turning Radius

2 Wheel Steer: 14.5m

4 Wheel Steer: 8.00m

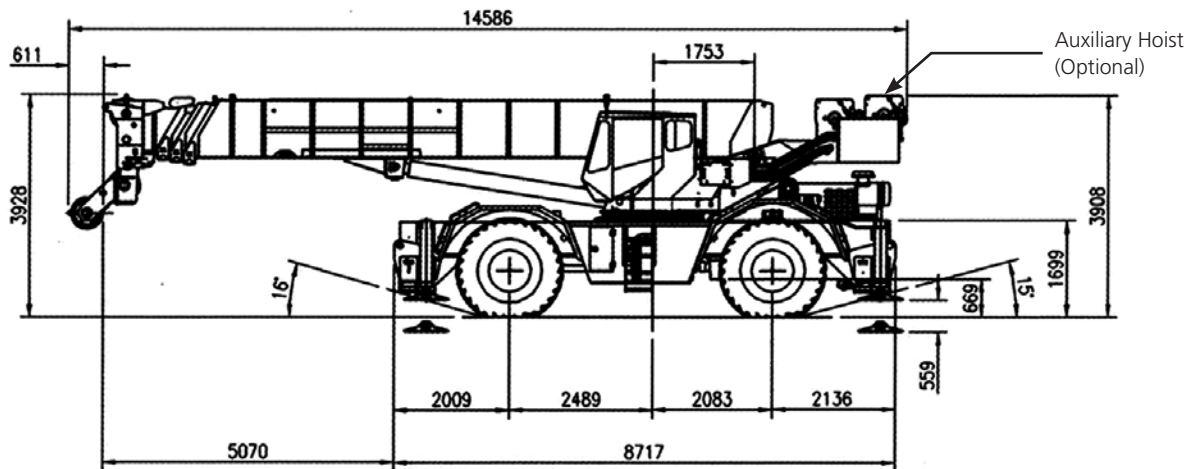
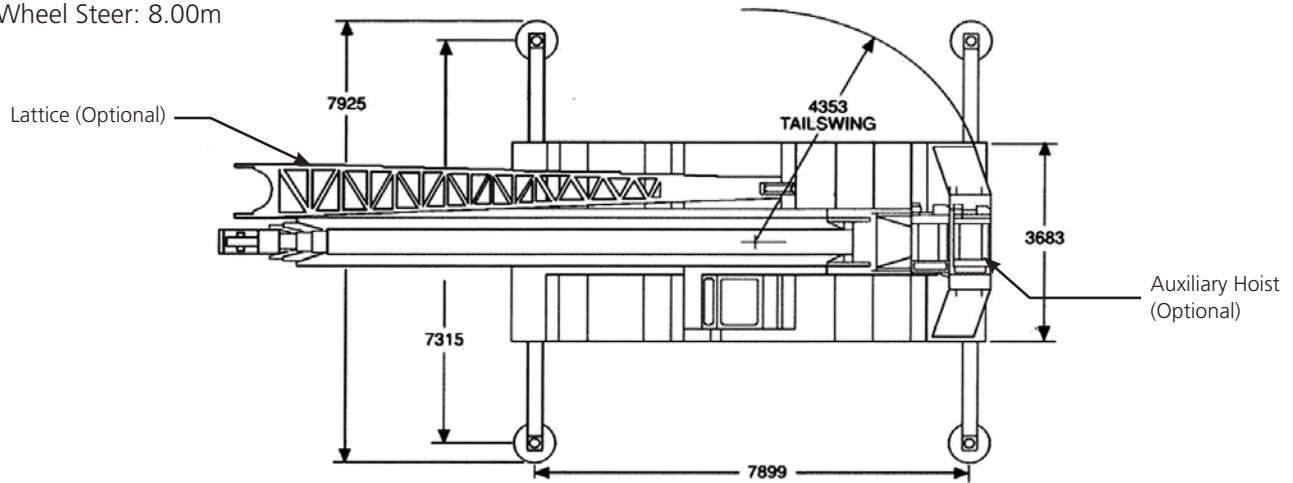

Dimensions in mm

Constant improvement and engineering progress make it necessary that we reserve the right to make specification, equipment and price changes without notice. The photographs/drawings in this document are just for illustrative purpose which may include optional equipment and accessories, which can be provided at an additional cost on request.

## TIL Limited

CIN: L74999WB1974PLC041725

### Registered & Corporate Office:

1, Taratolla Road, Garden Reach, Kolkata - 700024

Phone: + 91 33 2469 3732-6 / 6497 | 6633 2000 / 2845

Mobile: +91 9831839025 | +91 9831054573

Fax: + 91 33 2469 2143 / 3731

Email: [mktg-til@tilindia.com](mailto:mktg-til@tilindia.com)

### CHENNAI

Mobile: +91 9618562333

Email: [chennai.til@tilindia.com](mailto:chennai.til@tilindia.com)

### DELHI NCR

Mobile: +91 9831839025

Email: [MHGMarketing.Sahibabad@tilindia.com](mailto:MHGMarketing.Sahibabad@tilindia.com) | [mhgcs.Sahibabad@tilindia.com](mailto:mhgcs.Sahibabad@tilindia.com)

### KAMARHATTY

517, Barrackpore Trunk Road

Kolkata 700 058

Phone: +91 33 2553 1352 / 1882 | 6633 4000

Fax: +91 33 2553 2546 / 5971

Email: [MktDept.KMT@tilindia.com](mailto:MktDept.KMT@tilindia.com) | [til.kmt@tilindia.com](mailto:til.kmt@tilindia.com)

### KHARAGPUR

Vill. & P.O. Changual, Kharagpur

Dist: Paschim Medinipur 721 301, West Bengal

Phone: +91 32 2266 1101

### MUMBAI

Mobile: +91 9618562333

Email: [Mumbai.TIL@tilindia.com](mailto:Mumbai.TIL@tilindia.com) | [Mumbai.Custsupp@tilindia.com](mailto:Mumbai.Custsupp@tilindia.com)



**TIL has a pan-India network of offices with service engineers located in the close proximity of jobsites.**

Toll Free No: **1800 266 1535**

[www.tilindia.in](http://www.tilindia.in)

Technical Specification TIL/RT880/1222. This cancel Technical Specification TIL/RT880/1119.